

SUPPLY AIR DIFFUSER RIL

For high spaces



Suitable for ventilation and heating in shopping centres, sport arenas and industrial premises. The air distribution pattern can be adjusted to either horizontal or vertical. The surrounding air will be mixed into the vertical pattern.

Quick facts

	min.	max
Installation level, m - horizontal throw - vertical throw	4,0	12
Supply air temperature, °C - installation level 7 m - installation level 12 m		+20 +15

Order key

Supply air diffuser RIL-160

1 = size, 160 - 400

Material and surface treatment

Manufactured of sheet steel. As standard painted white RAL 9010. Other RAL colours are available at additional costs.

Quick guide

Recommended air flow for heating.

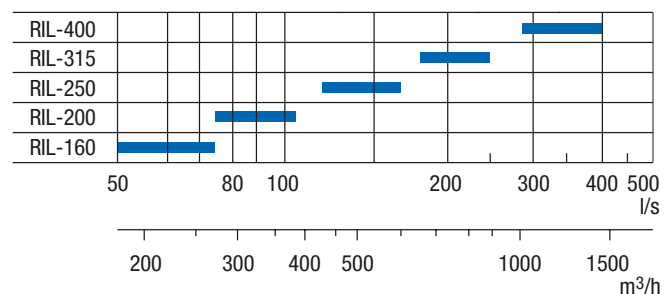

SUPPLY AIR DIFFUSER RIL

Performance

The graphs are not to be used for commissioning.

When the supply air Δt is over + 10 °C:
To ensure a proper vertical air pattern, the needed pressure drop should be at least 60 Pa.

Airflow - pressure drop - sound level

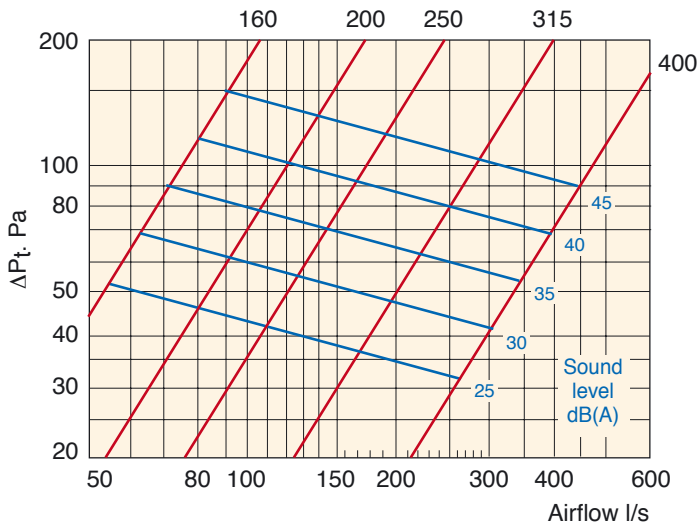

Sound power level L_w , dB

Correction factor K_{okt}

Size	63	125	250	500	1k	2k	4k	8k
160	-1	1	4	4	-2	-9	-14	-15
200	-3	0	4	3	-1	-8	-15	-16
250	-2	2	5	4	-3	-10	-13	-9
315	-1	0	3	2	-4	-7	-12	-7
400	2	5	4	2	-1	-9	-13	-9

Sound attenuation ΔL , dB

Size	Hz							
	63	125	250	500	1k	2k	4k	8k
160	17	12	7	3	2	3	3	3
200	15	10	5	3	2	3	3	3
250	12	8	5	1	2	3	2	3
315	9	7	2	1	0	2	2	3
400	8	5	1	2	1	2	2	3

Installation example

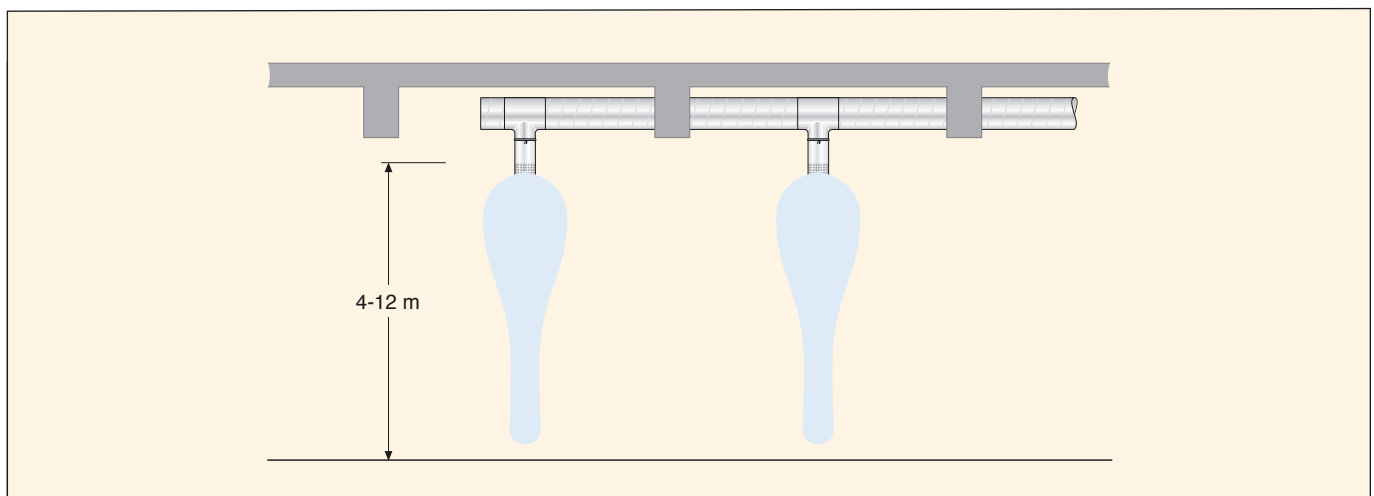

When needed, add a damper to the RIL.

SUPPLY AIR DIFFUSER RIL

Air flow - throw

The throw data is shown with isothermal supply air.

Vertical throw

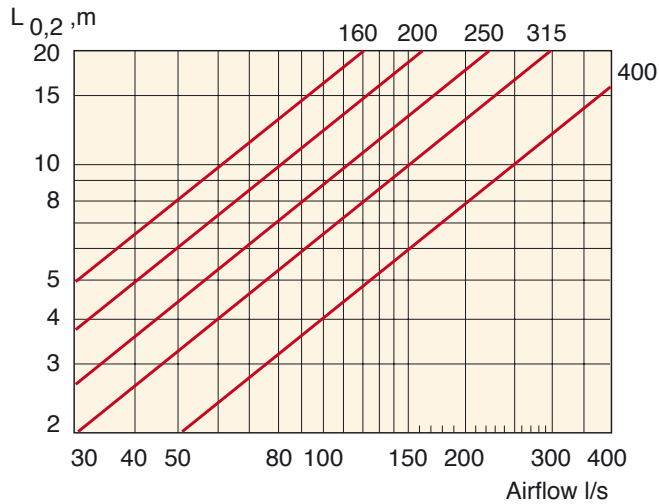

Horizontal throw

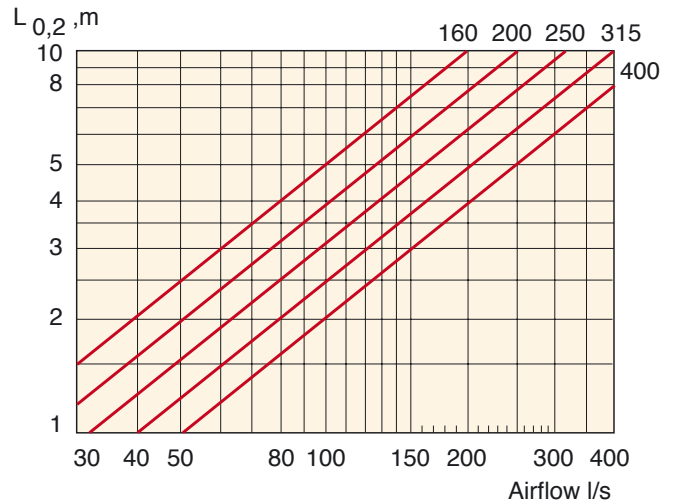

The supply air temperature will affect the vertical throw.

Adjusting the air distribution pattern does not affect the pressure drop or sound level.

Dimensions

Size	Ø d	Ø A	E	G
160	159	165	260	40
200	199	205	310	40
250	249	255	380	52
315	314	320	460	52
400	399	405	580	58

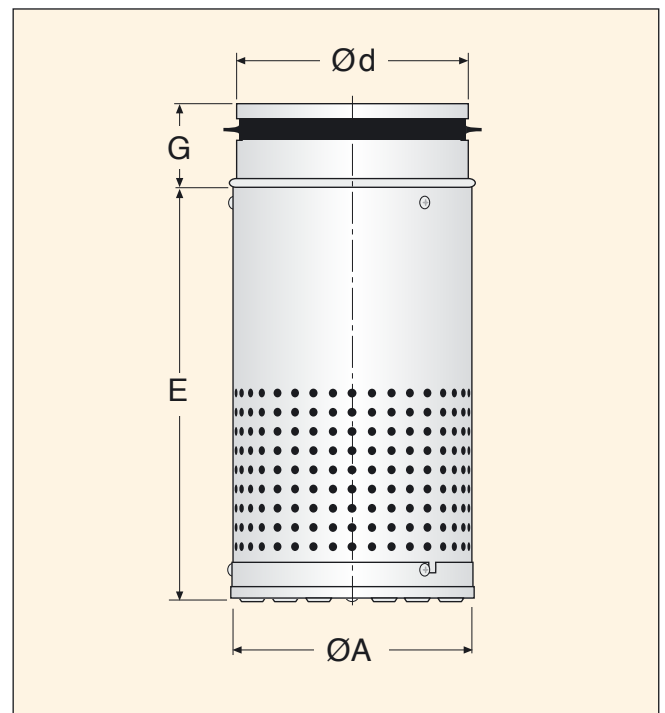

SUPPLY AIR DIFFUSER RIL

Installation

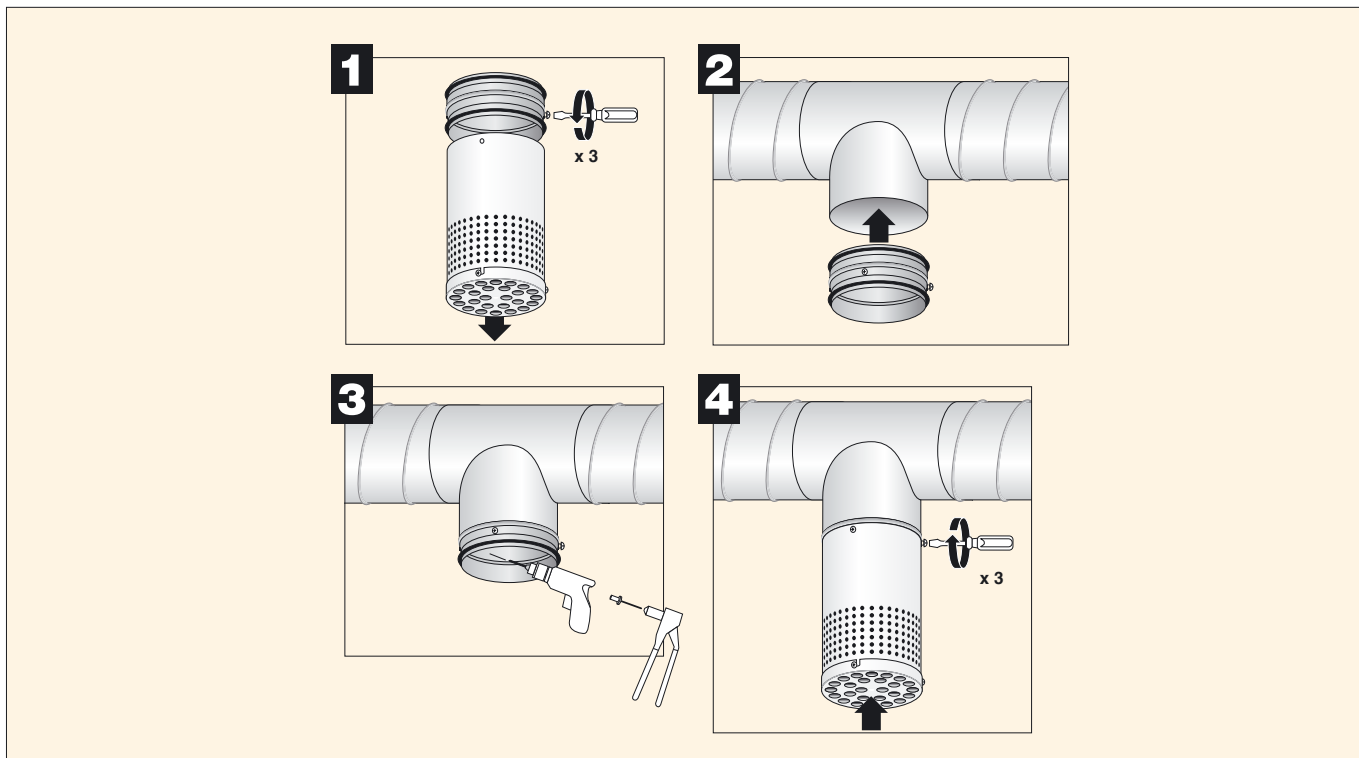

Adjusting the air distribution pattern

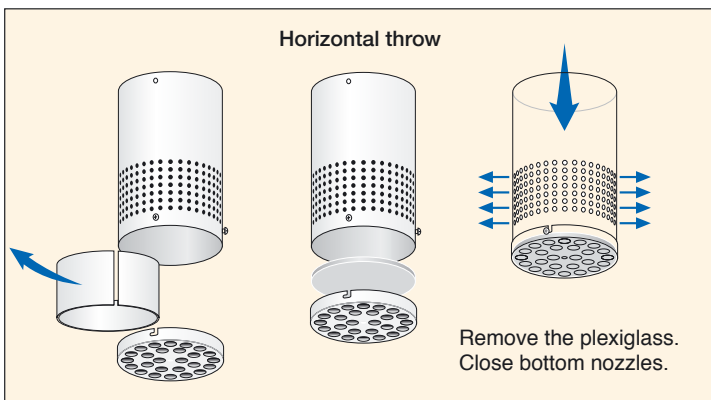
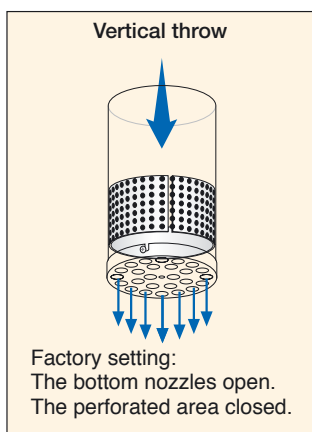
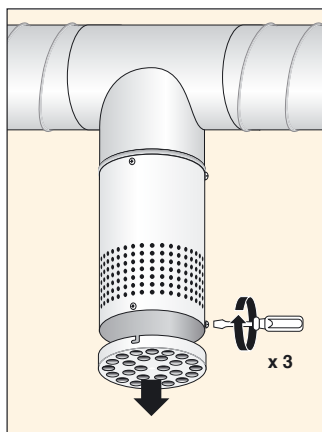

Measuring the air flow

Measure the pressure drop over the diffuser face.

The k-factors are shown in the RCL-commissioning guide.

