



# TWIST SUPPLY AIR DIFFUSER RIF

## Performance

The graphs are not to be used for commissioning

### Airflow - pressure drop - sound level

The graphs show the values for both vertical (1) and horizontal (3) air flow spread pattern.

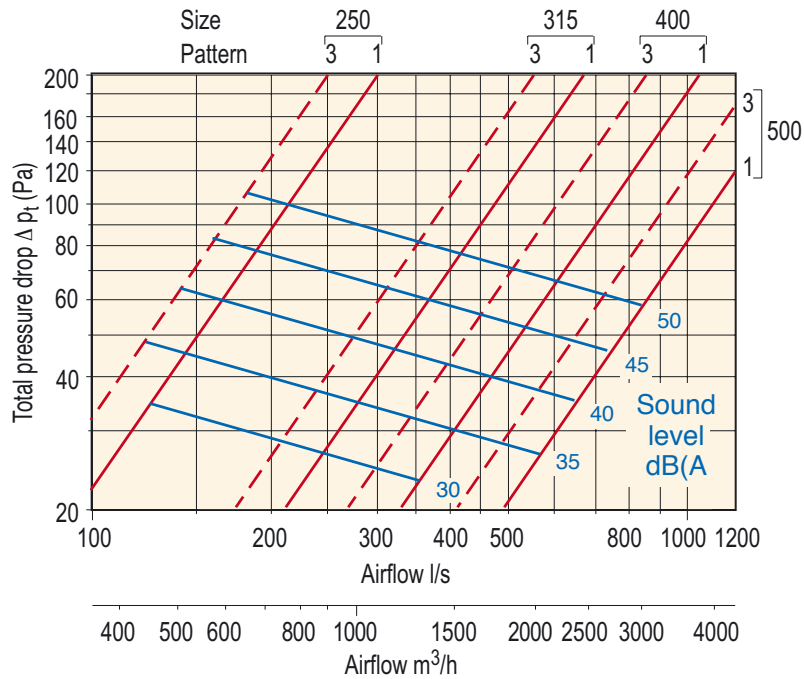

### Sound power level $L_w$ , dB

Size	Hz							
	63	125	250	500	1k	2k	4k	8k
250	5	10	9	3	1	-3	-8	-18
315	6	12	11	4	1	-3	-8	-17
400	10	13	11	4	3	-1	-9	-16
500	11	13	11	3	4	-1	-9	-16

### Sound attenuation $\Delta L$ , dB

Size	Hz							
	63	125	250	500	1k	2k	4k	8k
250	13	11	5	2	2	1	3	3
315	15	10	4	1	1	1	3	3
400	11	8	3	1	0	2	4	4
500	9	7	3	1	0	2	4	5

$$L_w = L_{A10} + K_{okt}$$

## Installation

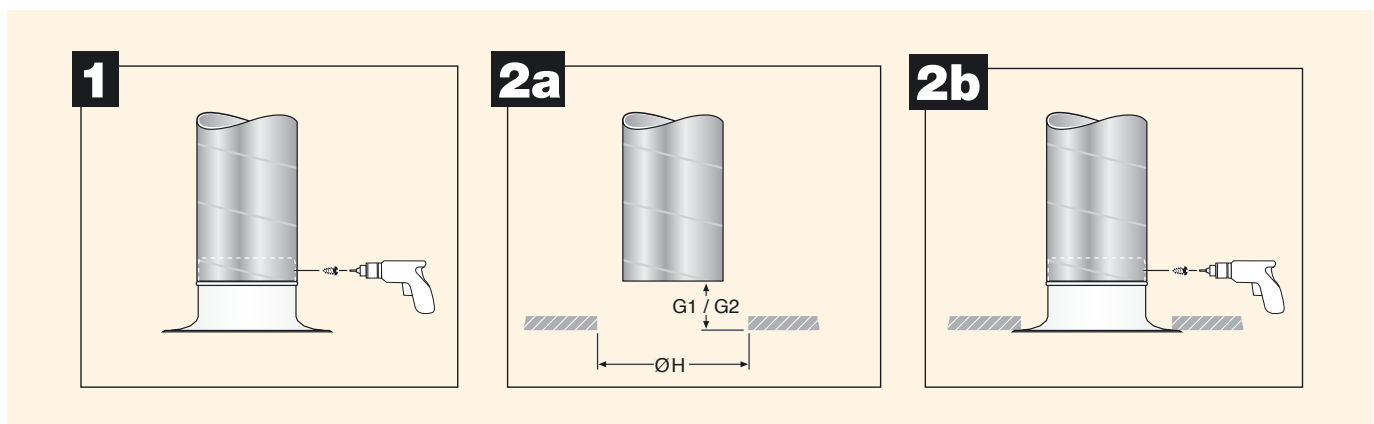

# TWIST SUPPLY AIR DIFFUSER RIF

## Vertical throw (1)

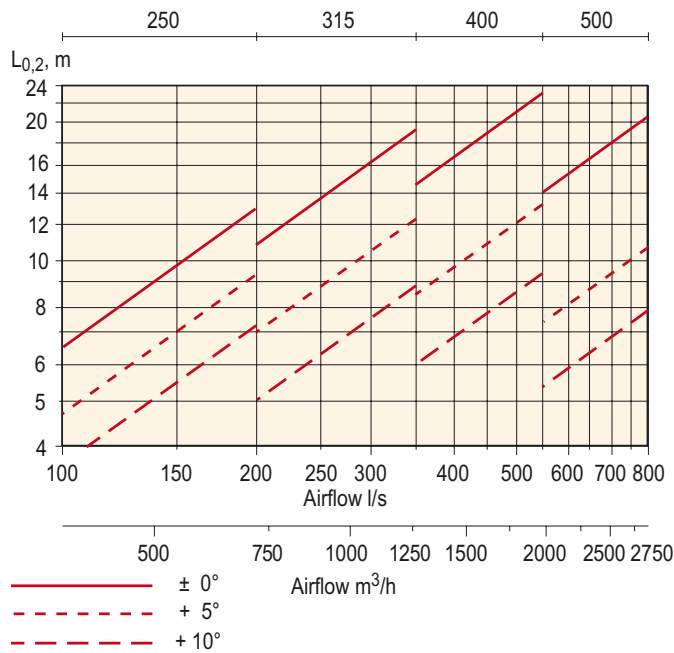

## Horizontal throw (3)

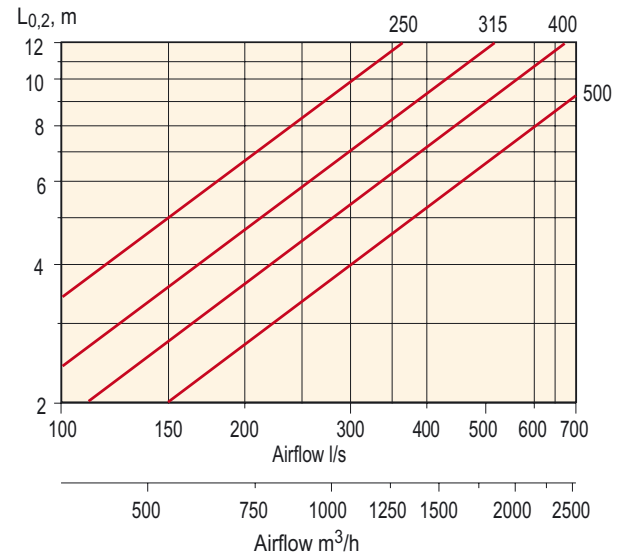

The throw length is increased by 20 % when the diffuser flange is installed against the ceiling

## The flow pattern is adjustable

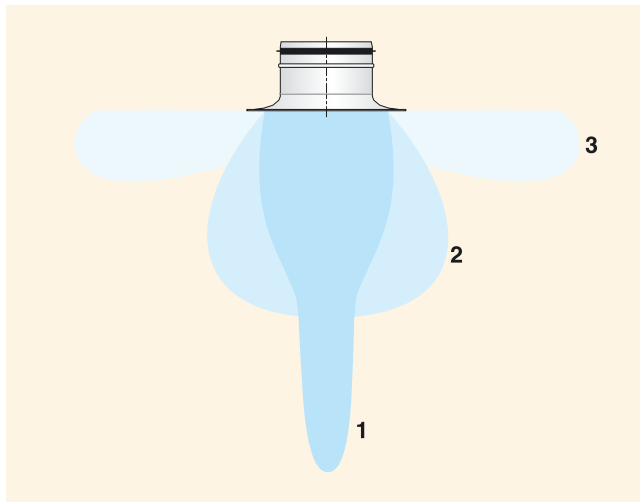

## How to adjust the spread pattern

### RIF

- Horizontal throw (factory setting): the vanes are in even division
- Vertical throw: open the locking screw in the middle of the diffuser and turn it to the right so that the vanes will be partly overlapping.

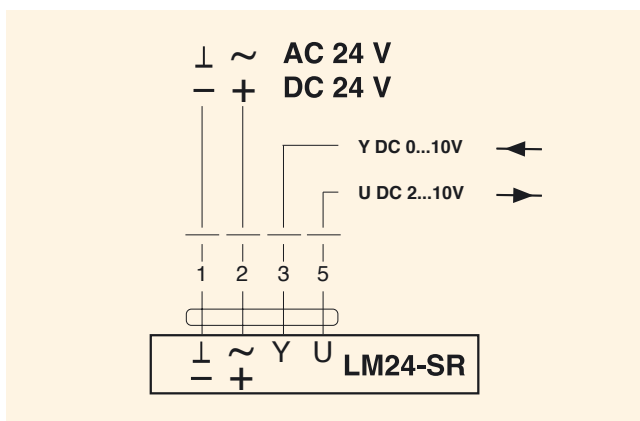

### RIF-M

The actuator will adjust the spread pattern, controlled for e.g. by a room thermostat.

# TWIST SUPPLY AIR DIFFUSER RIF

## Dimensions

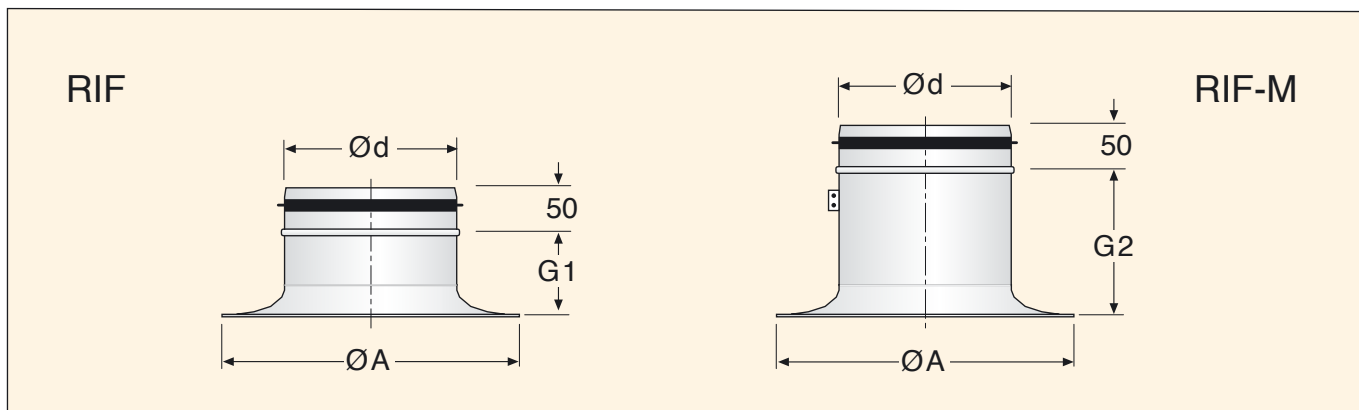

RIF ja RIF-M					Plenum box PTR			
Size	ød	øA	G1	G2	ød	L	M	E
250	249	440	125	255	249	400	350	300
315	314	532	140	270	314	500	420	365
400	399	618	170	300	399	600	500	450
500	499	750	210	340	499	700	600	550

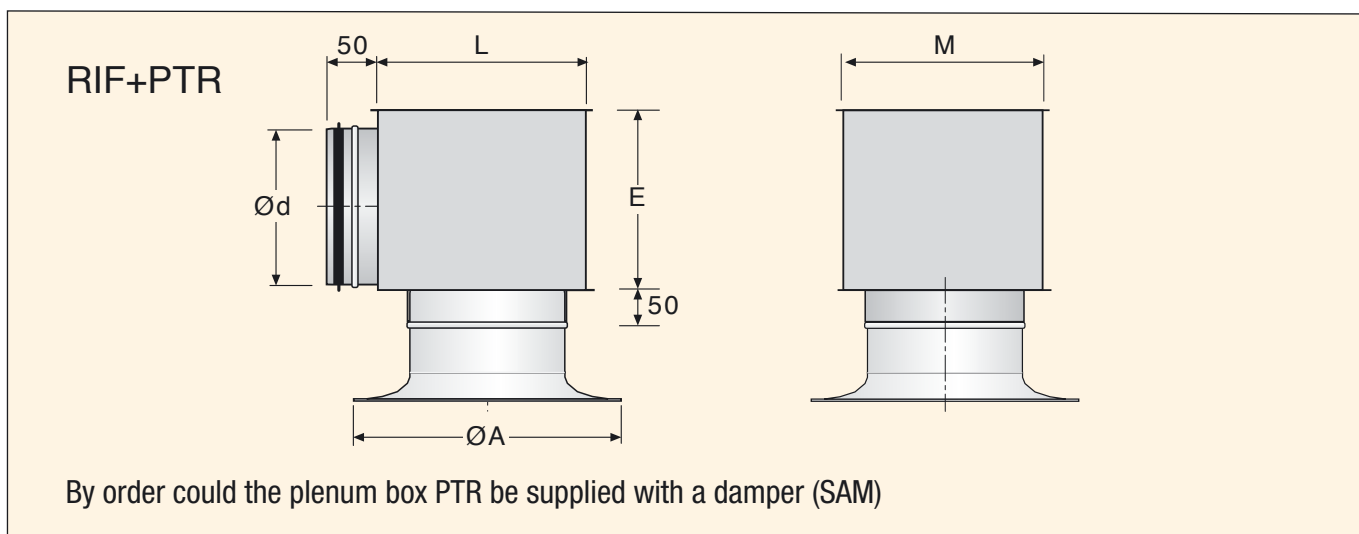

## Installation of the plenum box

